

Electronic circuit breaker with current limiting **BASIC SMART**



General Data

Nominal input voltage 24 Vdc
Output channels 2 / 4 / 8
Tripping current 0.5 - 6 A / 2 - 12 A
Active current limiting typ. 1,7 x I _{rated}
Ambient temperature -25 °C to +70 °C
Protection index IP 20
Efficiency typ. 99 %

Advantages

Adjustable tripping current for each output channel via current selector switch
Selective immediate switch off of defective circuits in the event of critical supply voltage
Sequential and load-dependent switching-on of channels
Comprehensive single-channel-diagnostics and remote switching on/off of each output channel via 2-wire-interface
Further diagnoses of input voltage and the current of each circuit
Group alarm contact

Applications

The BASIC SMART circuit breakers guarantee maximum system availability. In the event of overload, only the faulty current paths are reliably switched off without affecting the remaining circuits thanks to active current limiting to 1.7 times the rated current. The electronic circuit breaker distributes and monitors the load current over several current circuits. Overloads and short circuits on an output are reliably recognized. The electronics permit brief current peaks and switch longer overloads off. The rated current for each output can be individually set with a current selector switch accessible from the front. The outputs are activated depending on the time delay and load to avoid an overload current. If the rated current is exceeded for a certain amount of time, the output will be switched off automatically and can be reactivated after a waiting time (thermal relaxation) using the pushbutton or the remote signal input S1. The pushbutton can also be used to switch the output manually. It is possible to read out the state of each output using the three signal contacts. The state of each output is also indicated with a multi-colored LED.

Standards

Electronic circuit breaker
UL 508, UL 2367

Safety:
EN 60950-1, EN 50178,
EN/IEC 60204-1

EMC:
EN 61000-6-2, EN 61000-6-3

Safety extra-low voltage (SELV/PELV):
IEC 60364-4-41 (DIN VDE 0100-410)

378 Subject to change
CE acc. to 2004/108/EG (EMC-Directive)

Approvals



UL 2367 (E-File: E356250)UL 508 (E-File: E219022)GL



Electronic circuit breaker with current limiting **BASIC SMART**

Typ	PM-0824-120-0	PM-0824-240-0	PM-0824-240-2	PC-0824-480-0
Electrical data				
Input				
Input rated voltage	24 Vdc	24 Vdc	24 Vdc	24 Vdc
Input voltage range	18 - 30 Vdc	18 - 30 Vdc	18 - 30 Vdc	18 - 30 Vdc
Maximal residual ripple of supplied input voltage	3 %	3 %	3 %	3 %
Required input voltage for turning-on of outputs	19.5 V (Turn-off Threshold 18 V)	19.5 V (Turn-off Threshold 18 V)	19.5 V (Turn-off Threshold 18 V)	19.5 V (Turn-off Threshold 18 V)
Max. total input current	12 A	24 A	24 A	48 A
Max. input current for each pole of terminal	40 A	40 A	40 A	40 A
Over voltage protection	Suppressor diode 33 V	Suppressor diode 33 V	Suppressor diode 33 V	Suppressor diode 33 V
Stand-by current	32 mA @ 24 V	32 mA @ 24 V	22.7 mA @ 24 V	48 mA @ 24 V
Power losses in stand-by mode	0.77 W @ 24 V	0.77 W @ 24 V	0.55 W @ 24 V	1.15 W @ 24 V
Output				
Output rated voltage	24 Vdc	24 Vdc	24 Vdc	24 Vdc
Output rated current	2 x 0.5 - 6 A	4 x 0.5 - 6 A	2 x 2 - 12 A	8 x 0.5 - 6 A
Maximum voltage drop between input and output	145 mV @ 2 x 6 A	145 mV @ 4 x 6 A	210 mV @ 2 x 12 A	155 mV @ 8 x 6 A
Initialization time of module	250 ms	250 ms	250 ms	250 ms
Turn-on delay of outputs	Load dependent, min. 50 ms / max. 5 s	Load dependent, min. 50 ms / max. 5 s	Load dependent, min. 50 ms / max. 5 s	Load dependent, min. 50 ms / max. 5 s
Waiting periode after switch-off of an output	500 ms (short circuit) . . . 10 s (overload)	500 ms (short circuit) . . . 10 s (overload)	500 ms (short circuit) . . . 10 s (overload)	500 ms (short circuit) . . . 10 s (overload)
Max. power losses	2.5 W @ 2 x 6 A	4.3 W @ 4 x 6 A	5.58 W @ 2 x 12 A	8.6 W @ 8 x 6 A
Efficiency	99.0 %	99.0 %	99.0 %	99.0 %
Internal output fuse	15 A	15 A	15 A	15 A
Resistance to reverse feed max.	35 Vdc	35 Vdc	35 Vdc	35 Vdc
Parallel use of outputs	Not allowed	Not allowed	Not allowed	Not allowed
Serial use of outputs	Not allowed	Not allowed	Not allowed	Not allowed
Signaling				
Status indicator	LED (red, green, orange)	LED (red, green, orange)	LED (red, green, orange)	LED (red, green, orange)
Signal input S1	24 Vdc (On/Off/Reset)	24 Vdc (On/Off/Reset)	24 Vdc (On/Off/Reset)	24 Vdc (On/Off/Reset)
Signal output S2	24 Vdc, max. 25mA (status output channels)	24 Vdc, max. 25mA (status output channels)	24 Vdc, max. 25mA (status output channels)	24 Vdc, max. 25mA (status output channels)
Signal output S3	24 Vdc, max 25mA (Common signalling output)	24 Vdc, max 25mA (Common signalling output)	24 Vdc, max 25mA (Common signalling output)	24 Vdc, max 25mA (Common signalling output)
Approvals				
Approvals	cURus, cULus, GL	cURus, cULus, GL	cURus, cULus, GL	cURus, cULus, GL
Environment				
Storage temperature	-25 °C to +85 °C	-25 °C to +85 °C	-25 °C to +85 °C	-25 °C to +85 °C
Ambient temperature	-25° C to +70° C	-25° C to +70° C	-25° C to +70° C	-25° C to +70° C
Derating	-	-	-	-
Type of cooling	Natural convection	Natural convection	Natural convection	Natural convection
Required minimum spacing (left/right)	0 mm	0 mm	0 mm	0 mm
Required minimum spacing (over/under)	40 mm	40 mm	40 mm	40 mm
Safety and protection				
Protection index	IP 20	IP 20	IP 20	IP 20
Safety class	III, without PE connection	III, without PE connection	III, without PE connection	III, without PE connection
Degree of pollution	2	2	2	2
Order numbers				
Order Number	PM-0824-120-0	PM-0824-240-0	PM-0824-240-2	PC-0824-480-0

1.1

1.2

1.3

2.1

2.2

3.1

3.2

3.3

4.0

5.1

5.2



Electronic circuit breaker with current limiting **BASIC SMART**

Mechanical data	Typ	Mounting position	Terminals signalling, 1) direct plug-in technology Push-in 2) pluggable, WAGO series 721	Input terminals (2 x "1"), 1) direct plug-in technology Push-in 2) pluggable, WAGO series 721	Input terminals (2 x "1"), 1) direct plug-in technology Push-in 2) pluggable, WAGO series 831	Output terminals ("1"), 1) direct plug-in technology Push-in 2) pluggable, WAGO series 721	Weight	Dimension picture (in mm)							
								A	B	C	D	E	F	G	
	PM-0824-120-0	horizontal for standard rail DIN TS35	1) max 2,5 mm ²	1) max 2,5 mm ²	1) max 6 mm ²	1) max 2,5 mm ²	0.2 kg	1	90	45	45	3	3.5	91.5	99
	PM-0824-240-0	horizontal for standard rail DIN TS35	1) max 2,5 mm ²	1) max 2,5 mm ²	1) max 6 mm ²	1) max 2,5 mm ²	0.2 kg	2	90	45	45	3	3.5	91.5	99
	PM-0824-240-2	horizontal for standard rail DIN TS35	1) max 2,5 mm ²	1) max 2,5 mm ²	1) max 6 mm ²	1) max 2,5 mm ²	0.2 kg	3	90	45	45	3	3.5	91.5	99
	PC-0824-480-0	horizontal for standard rail DIN TS35	1) max 2,5 mm ²	1) max 2,5 mm ²	1) max 6 mm ²	1) max 2,5 mm ²	0.4 kg	3	127	63.5	42	3	116.5	124	-
	PM-0824-480-0	horizontal for standard rail DIN TS35	1) max 2,5 mm ²	1) max 2,5 mm ²	1) max 6 mm ²	1) max 2,5 mm ²	0.2 kg	4	90	45	45	3	3.5	91.5	99

Dimension pictures

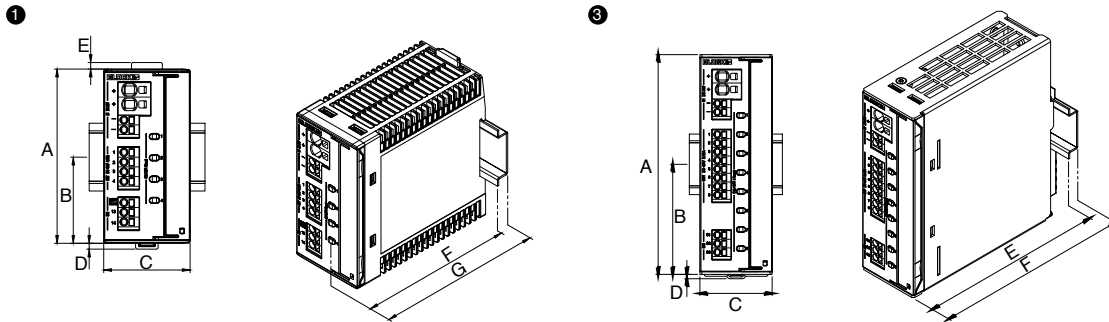

1.1

1.2

1.3

2.1

2.2

3.1

3.2

3.3

4.0

5.1

5.2